

# Sentinel Series

## Ducted Cooling Systems

Protect your wine investment. Wine Guardian's Sentinel Series units are the **strongest and most energy-efficient** wine cellar cooling systems on the market. They provide **optimal temperature and humidity control** for both commercial and residential cellars with a design that allows for easy installation and service. Ducted systems are self-contained units that contain the evaporator, fans, compressor, condenser, and controls. This means that installation is entirely indoors. These units can be placed outside the cellar, so the system can cool the space while remaining unseen and unheard.

The Sentinel Series ducted cooling systems have a broad range of capacities at wine cellar conditions (55-58°F/12-14°C). An optional humidifier can be installed with the ability to achieve 55-65% relative humidity. For more information about our unit specifications, view our specification sheet.

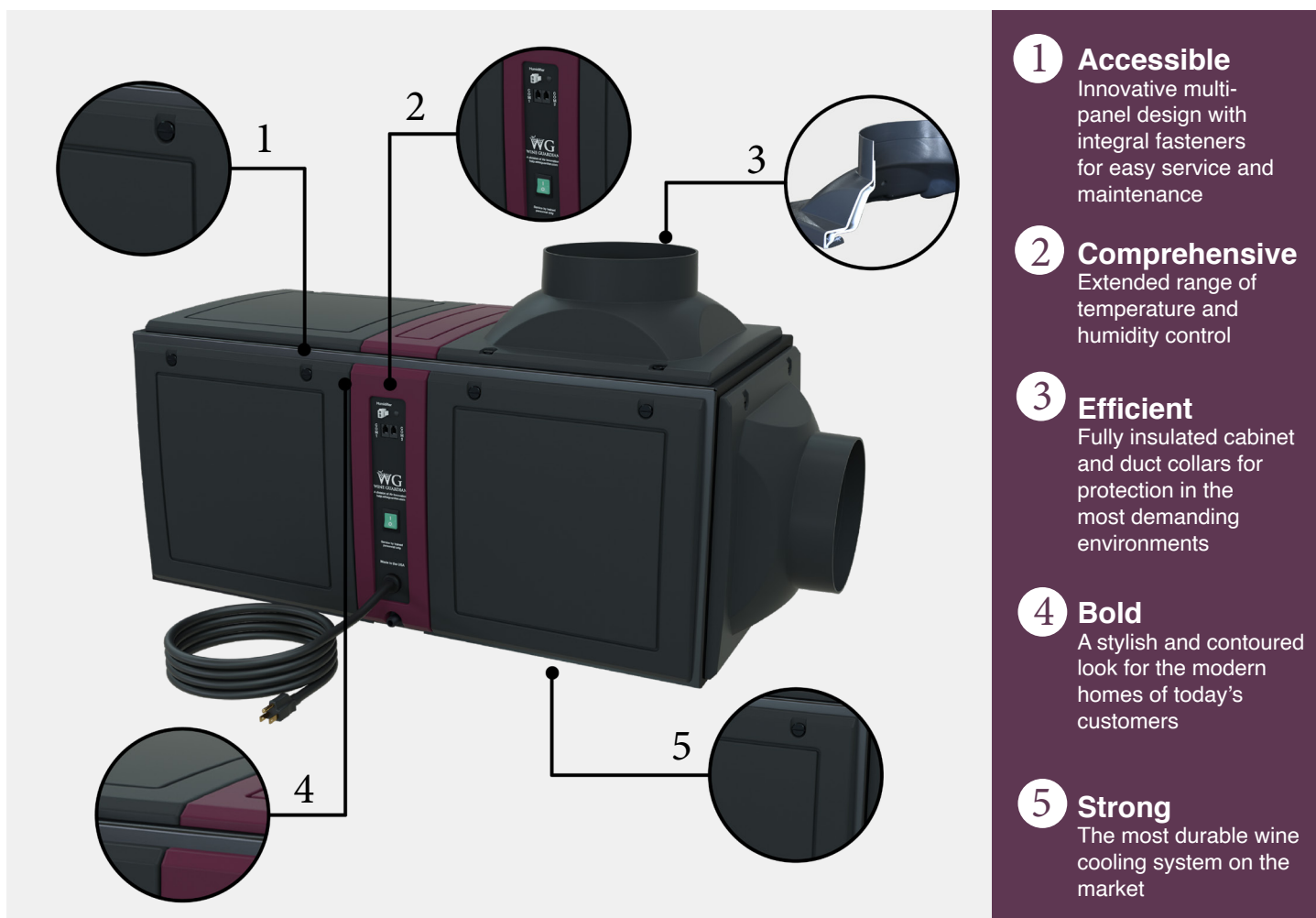

- 1 Accessible**  
Innovative multi-panel design with integral fasteners for easy service and maintenance
- 2 Comprehensive**  
Extended range of temperature and humidity control
- 3 Efficient**  
Fully insulated cabinet and duct collars for protection in the most demanding environments
- 4 Bold**  
A stylish and contoured look for the modern homes of today's customers
- 5 Strong**  
The most durable wine cooling system on the market

Wine Guardian Factory & Headquarters - USA:  
7000 Performance Dr, North Syracuse, NY 13212  
wineguardian.com | info@wineguardian.com  
Designed and Built in the USA

Wine Guardian European Office:  
Pestalozzistrasse 2, CH-8201 Schaffhausen,  
Switzerland



**Sentinel  
Series**

# Wine is your passion. *Preserving it is ours.*

## Accessible

Composite multi-panel design with integral captive quarter-turn fasteners allows for **ease of access** and serviceability. Interchangeable duct collars and solid panels can be simply configured during installation.

## Comprehensive

Our cooling systems offer a **wide range of control**, so you can match our units to your specific needs. Up to 3 optional remote sensors and 2 remote interface controllers with Wireless2Base™ technology can be added to your unit for easy monitoring and control of your cellar or in whatever room is most convenient for you.

## Efficient

The ducted system chassis features up to **three times more insulation** than previous versions. New stronger, double wall insulated duct collars insulate 42% more to help reduce temperature loss and condensation even in the most demanding environments.

## Bold

A **sleek and modern look** to compliment any wine cellar design.

## Strong

The Sentinel Series is made of the highest UL rated composite material, features an all aluminum chassis, and contains coated coils to ensure **product durability**. It is five times stronger than our previous model. The unit's construction prevents dents and scratches from installation and shipping.

### Options and Accessories:

- Water-cooled systems
- Humidification
- Electric heat
- Extreme climate protection
- Remote control, monitoring and sensing
- Duct kits and grilles
- Extended warranties

\*Not all options are available for all units. Contact a distributor for more information.



Do not attempt. Trained personnel in a controlled environment.



Wine Guardian Factory & Headquarters - USA:  
7000 Performance Dr, North Syracuse, NY 13212  
wineguardian.com | info@wineguardian.com  
Designed and Built in the USA

Wine Guardian European Office:  
Pestalozzistrasse 2, CH-8201 Schaffhausen,  
Switzerland

  
WINE GUARDIAN®

**Sentinel  
Series**